

Randomized Smoothing Networks

Maurice Herlihy, Brown University

Srikanta Tirthapura, Iowa State University

Distributed Load Balancing

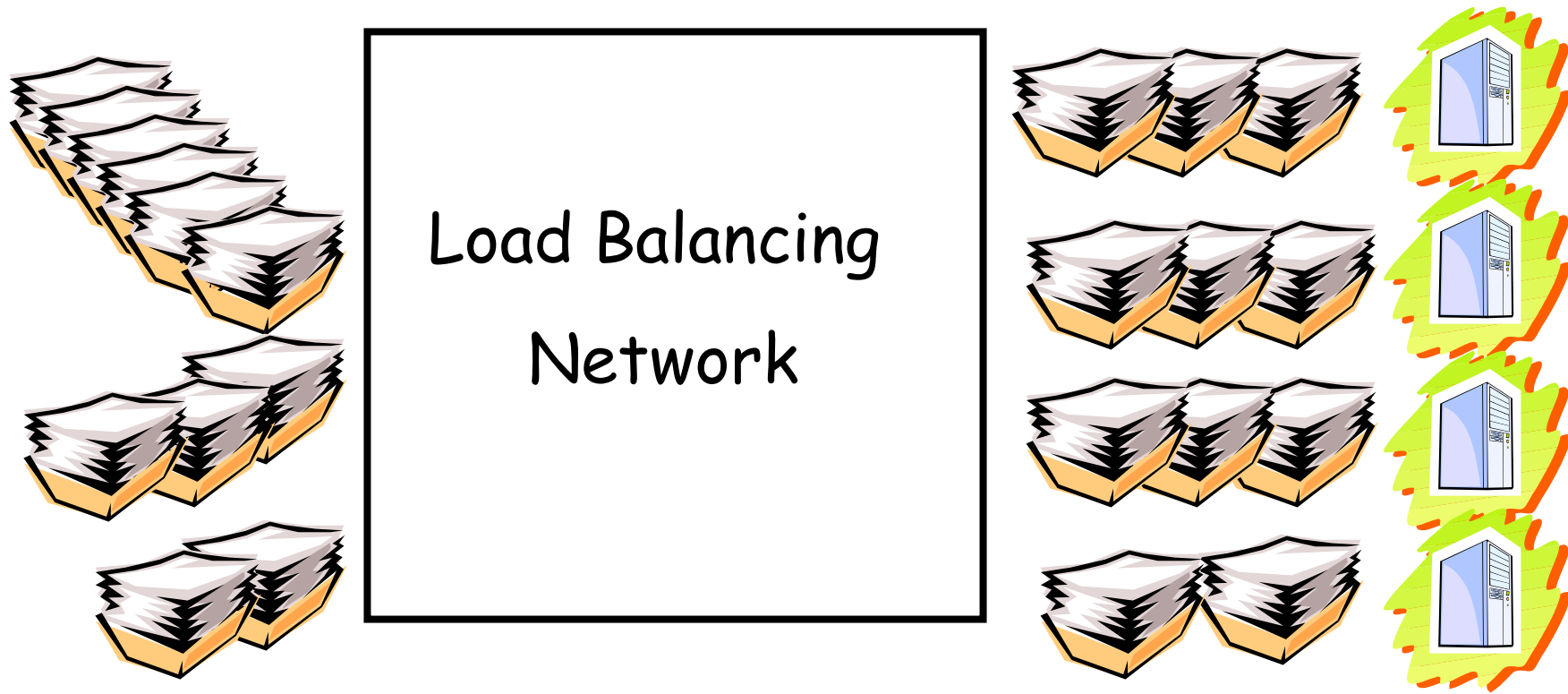

Example: Routing Tasks to Processors on a Grid

Smoothing Networks

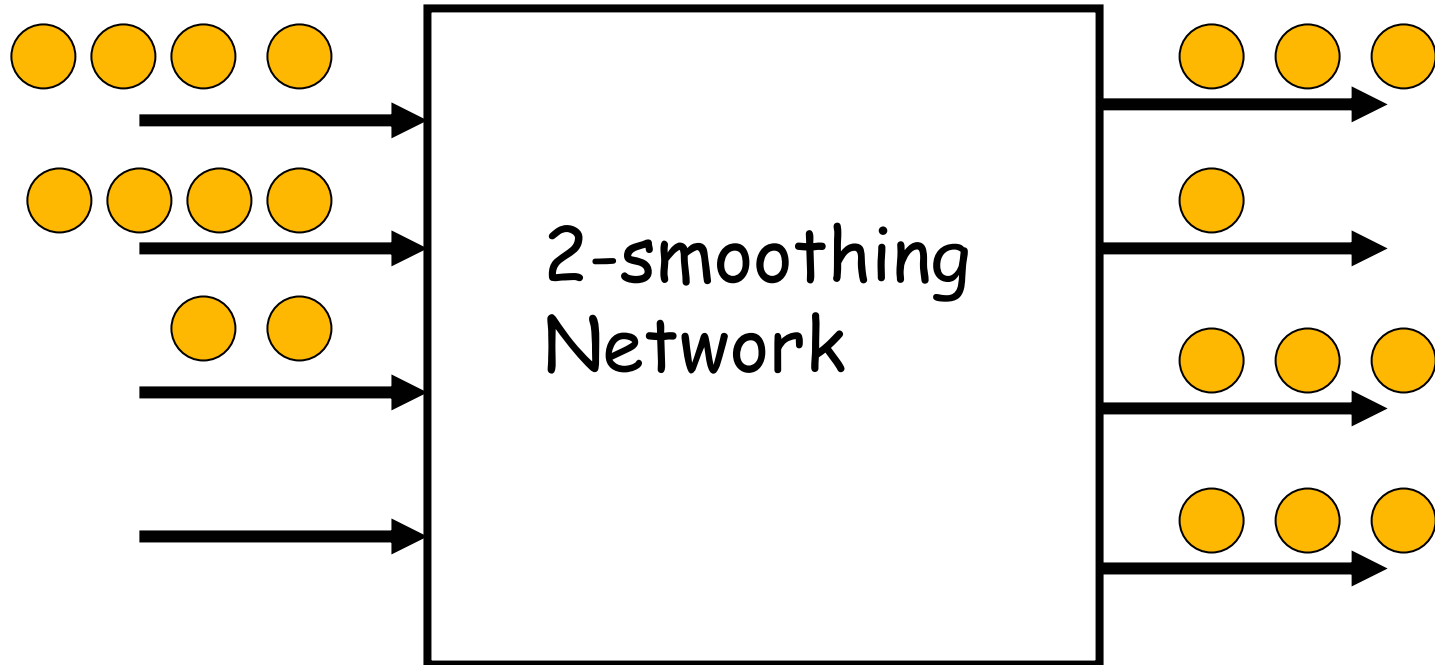

In a **k-smoothing Network**, the numbers of Tokens on different output wires differ by at most k

How to Build Smoothing Data Structures?

- Centralized Solution
- Random routing
 - Distributed and local
 - The smoothness can diverge without bound as more tokens enter the network

- Balancing Networks

Overview of Talk

- Describe Smoothing Networks built out of balancers
- Our Result: Randomized Smoothing Networks better than Deterministic Ones
- Analysis of the Randomized Butterfly (or Block) network

Basic Component: Balancer

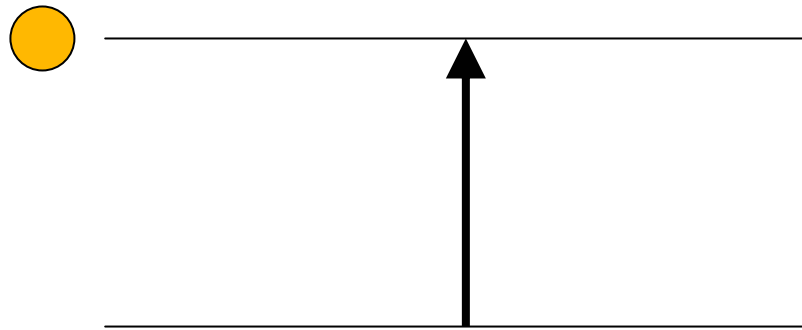

Balancer

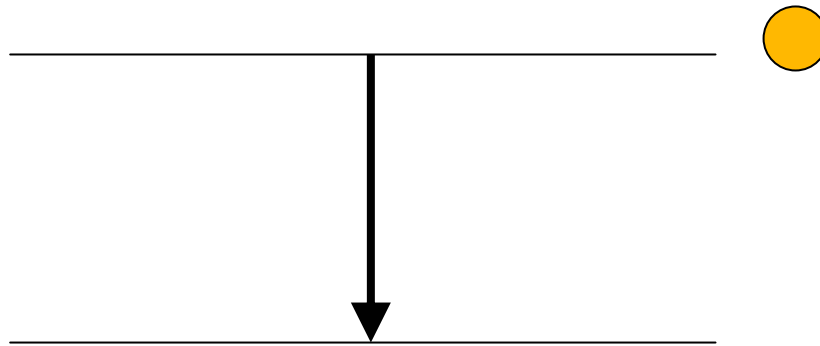

Balancer

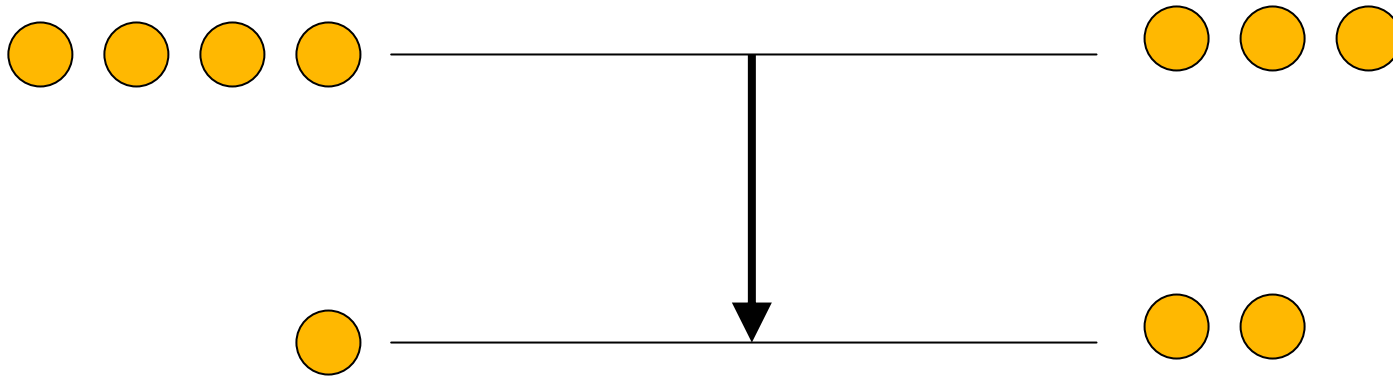

Smoothing Networks: Scalable Distributed Data Structures

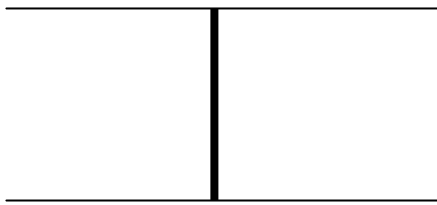

Bitonic[2]

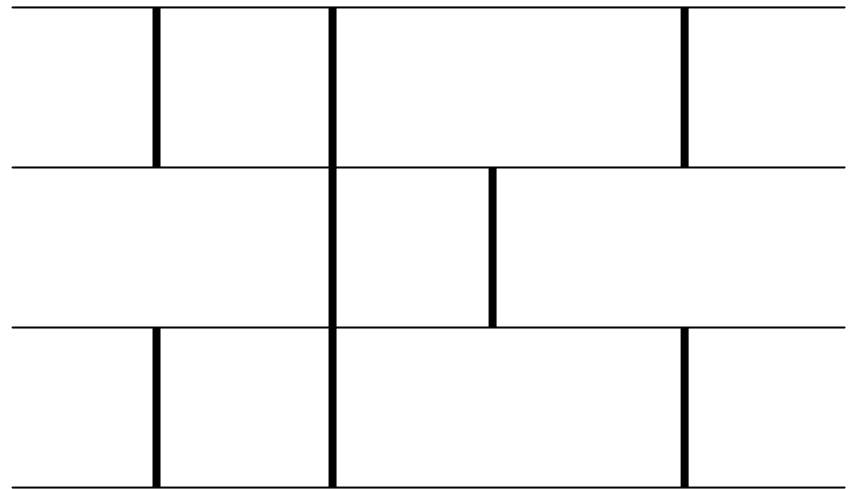

Bitonic[4]

Prior Work: Deterministic Smoothing Networks

- The Network Balancers are Initialized in a very specific way
- (Usually) All balancers are pointing up

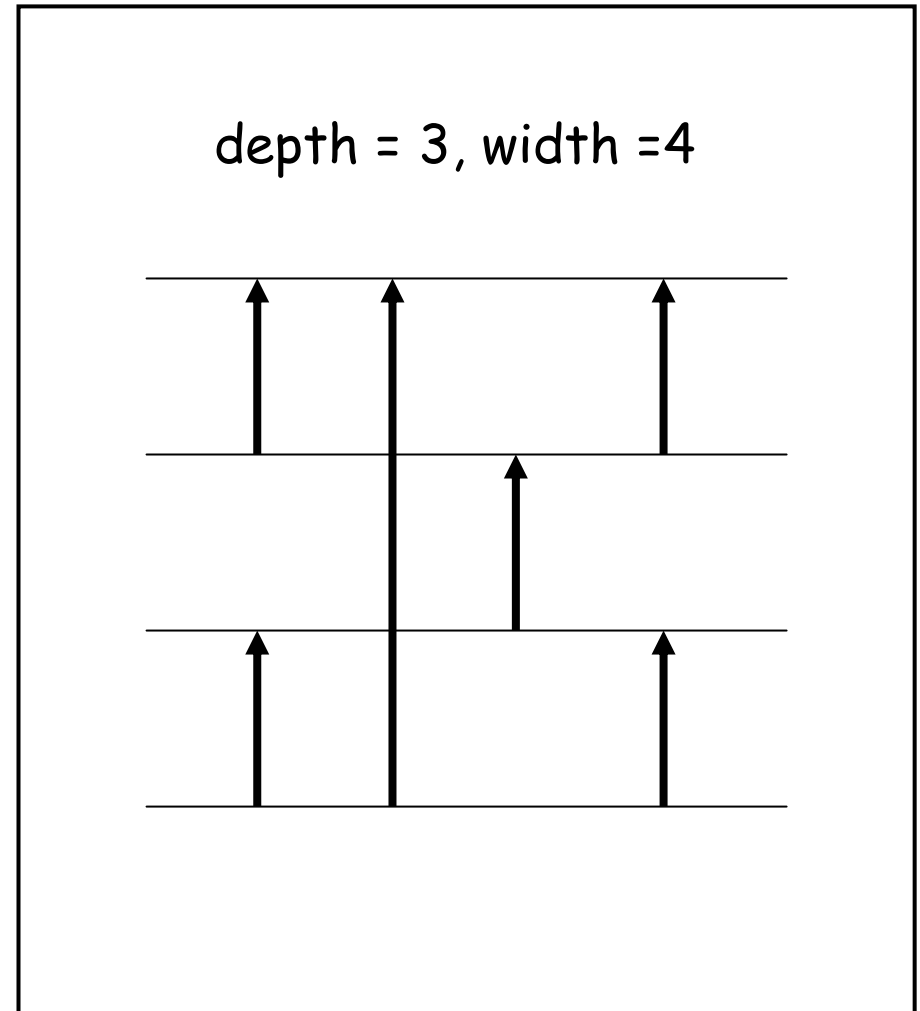

Our Work: Randomized Smoothing Networks

- Random balancers – initialized as follows
 - With prob = $\frac{1}{2}$, up
 - With prob = $\frac{1}{2}$, down
- Resulting Initial Network State also random
- How good are the smoothing properties of randomized networks?

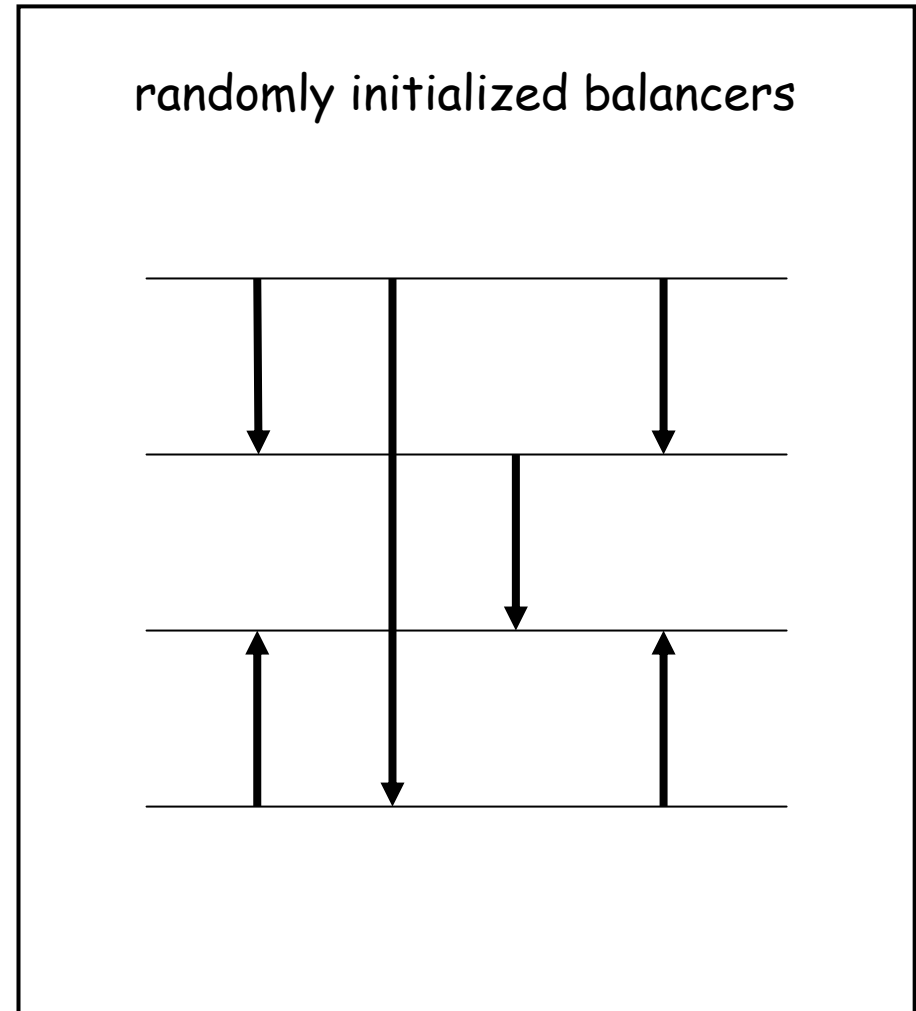

Benefits of Randomized Networks

1. Easy Initialization

- Each balancer sets itself to a random state
- Completely Local Actions

2. Easy to recover from faults

- Global reconfiguration unnecessary

3. Better Smoothing Properties

Butterfly Network: Inductive Construction



Width = 2

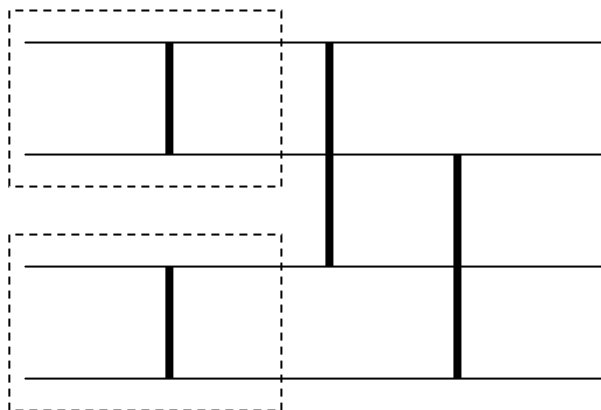

Width = 4

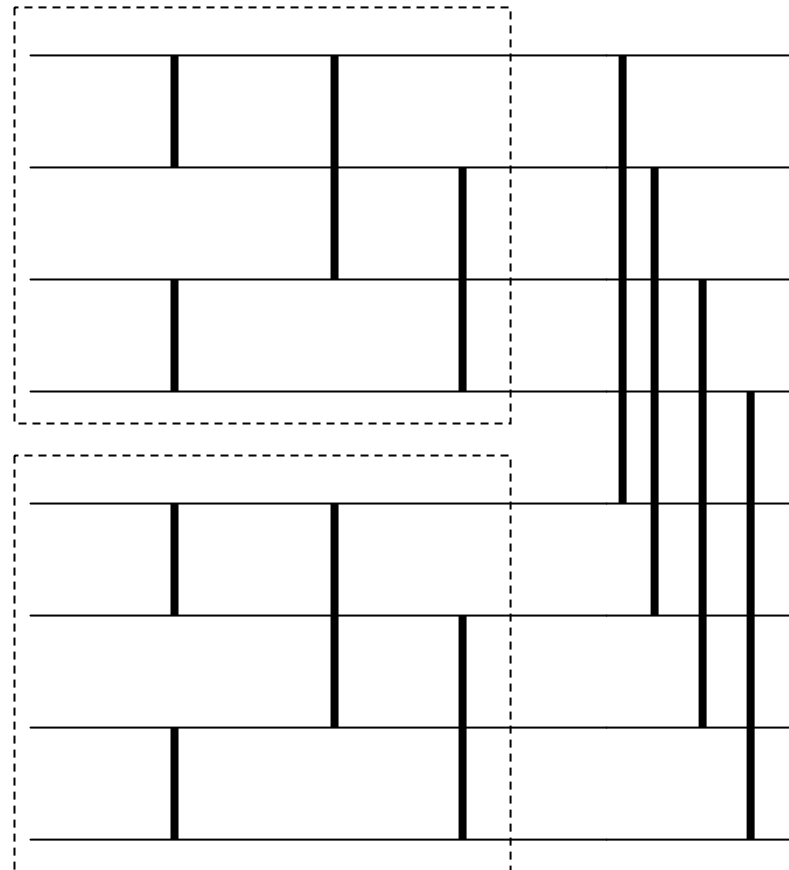

Width = 8

Our Main Result

- Many Randomized Networks produce much smoother outputs than Regular Deterministically Initialized Networks
- For a **Butterfly network** of width w :
 - The output of a randomized network has smoothness $2.83\sqrt{\log w}$ with high probability
 - For any deterministic initialization, worst case output smoothness is no better than $O(\log w)$

Implications

- $2.83\sqrt{\log w}$ nearly constant for practical purposes
 - If $w = 10^9$, this is 14
 - Smoothness independent of the number of tokens entering the network
- Network is very simple and easy to construct
- No further constants hidden in $O(\dots)$

Previous Work

- Aspnes Herlihy and Shavit, 1991
 - Bitonic and Periodic Counting networks (which are also 1-smoothing)
 - Isomorphic to sorting networks
 - Width w , depth $O(\log^2 w)$
- Klugerman and Plaxton, 1992
 - Better depth constructions of counting networks
 - Width w , depth $\approx O(\log w)$
 - Constants are very high, not practical

Previous Work (2)

- Aiello, Venkatesan and Yung, 1993
 - Counting and Smoothing Networks using random and deterministic balancers
 - An alternate definition of a randomized balancer
 - Our results apply to their definition of random balancers also
 - In contrast, we use only randomized balancers
- Herlihy and Tirthapura, 2003
 - Worst case smoothness of deterministic Butterfly, Periodic and Bitonic networks
 - Matching upper and lower bounds
 - Self-stabilizing constructions

Analysis: Random balancer

a, b = numbers of tokens entering the balancer

c, d = numbers of tokens exiting the balancer

$$\begin{aligned} r &= +\frac{1}{2} \text{ with probability } \frac{1}{2} \\ &= -\frac{1}{2} \text{ with probability } \frac{1}{2} \end{aligned}$$

$$\begin{aligned} c &= (a+b)/2 + D(a+b) r \\ d &= (a+b)/2 - D(a+b) r \end{aligned}$$

D = odd characteristic function

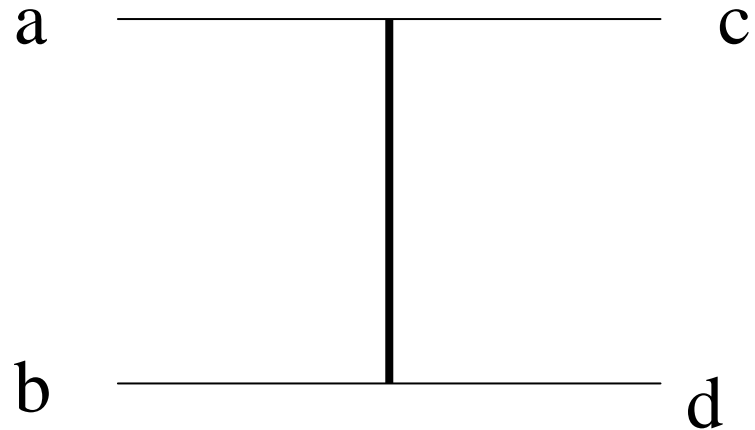

Analysis (2): Butterfly[8]

y_1 depends only on
the balancer decisions
 $r_1 \dots r_7$ and on $x_1 \dots x_8$

$$y_1 = f(x_1, x_2, x_3, \dots, x_8, \\ r_1, r_2, \dots, r_7)$$

$$E[y_1] = (x_1 + x_2 + \dots + x_8) / 8$$

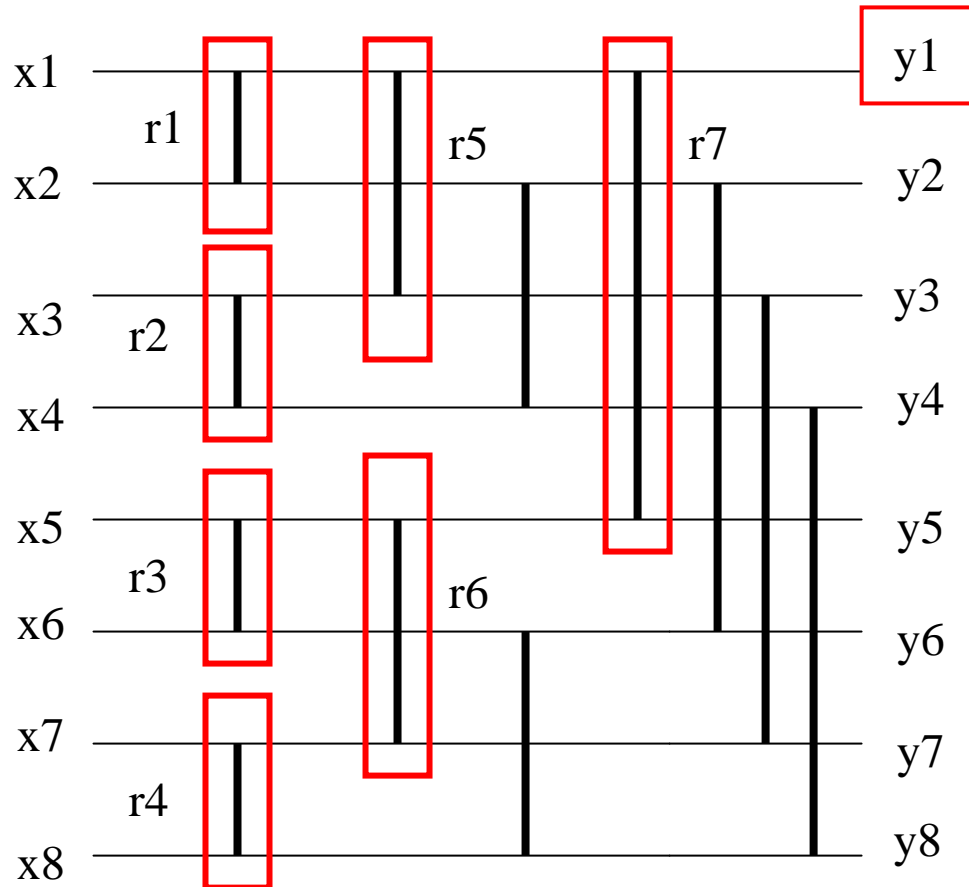

Width = 8

Analysis (3)

Random variable y_1 is hard to work with directly

Define Alternate Random Variable z_1 :

$$\begin{aligned} z_1 = & (r_1+r_2+r_3+r_4)/4 \\ & + (r_5+r_6)/2 \\ & + r_7 \\ & + (x_1+\dots+x_8)/8 \end{aligned}$$

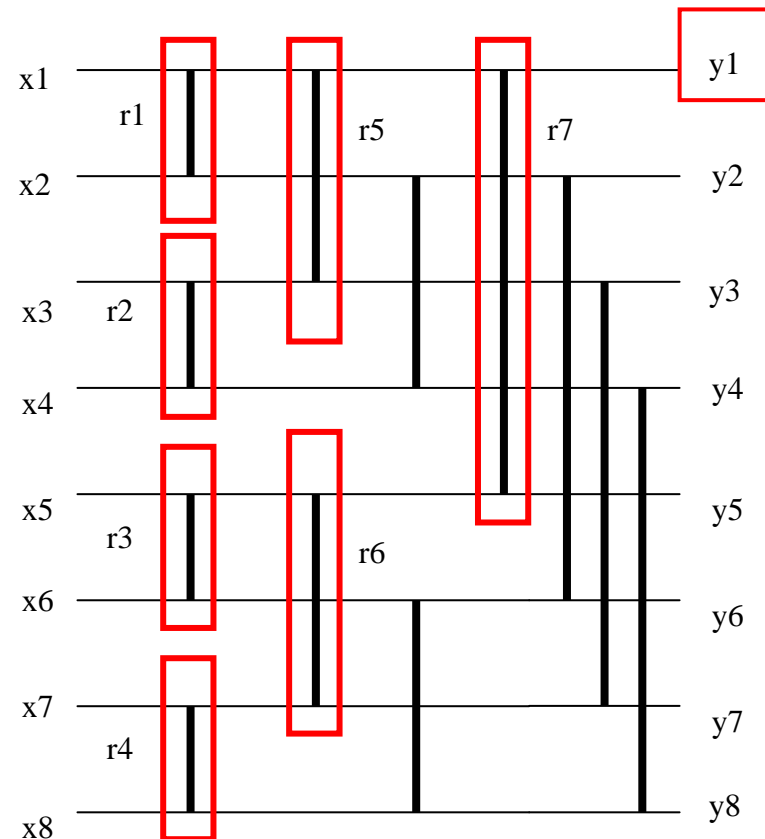

Width = 8

Analysis (4)

- Random Variable z_1 is easier to handle, since it is a linear function of r_1, r_2, \dots, r_7

$$\Pr[y_1 > \delta] \leq 2 \Pr[z_1 > \delta]$$

- Use Hoeffding's inequality to bound the tail of z_1 , and hence y_1

Theorem

The output of Butterfly[w] with random balancers is $2.83\sqrt{\log w}$ smooth with probability at least $(1-4/w)$, irrespective of the input sequence

Contrast: For any deterministic initialization, there exist inputs which lead to $(\log w)$ smooth outputs

Conclusions

- Simple network (butterfly) with small depth and very good smoothness
- Easy, local reconfiguration after faults

Open Questions

- Do there exist simple, log-depth networks with constant output smoothness (with high probability)?
- Can the upper bound on the butterfly network be improved?
- Matching Lower bounds?
- Smoothing networks for tokens of unequal weights?

