

POWER SYSTEM DYNAMICS - OVERVIEW

F. P. de Mello
Power Technologies, Inc.
Schenectady, New York

INTRODUCTION

Dynamics of power systems cover a wide spectrum of phenomena, electrical, electro-mechanical and thermomechanical in nature. The power system process can encompass entire nations and continents and, therefore, involve a very high dimension of interacting systems with an immense array of variables.

An overview of the power system process was presented in Reference 1 where dynamic problems were classified under the major categories of (1) electrical machine and system dynamics, (2) system governing and generation control, and (3) prime-mover energy supply system dynamics and controls. Figure 1 illustrates the nature of problems in these categories.

A convenient visualization of the process showing coupling between major variables is developed in the block diagram of Figure 2. In this diagram, one of the interfaces between mechanical and electrical systems is recognized in the shaft powers to generating units.

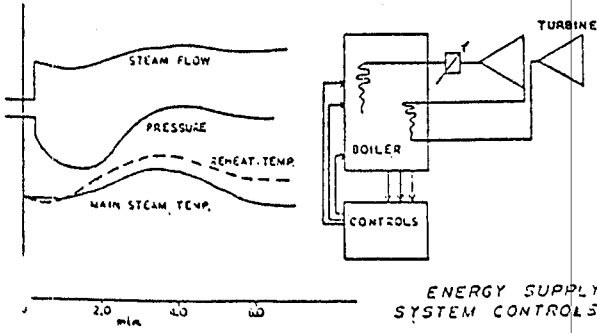
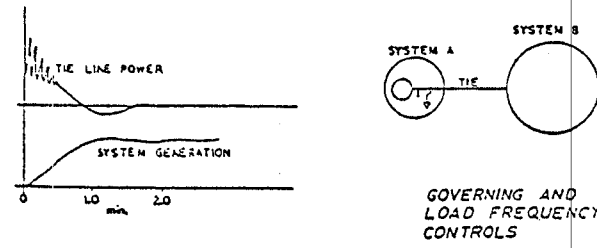
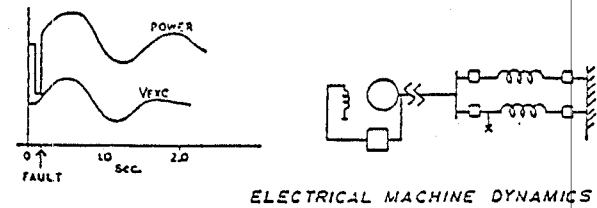

Figure 1. Classes of Power System Dynamic Problems

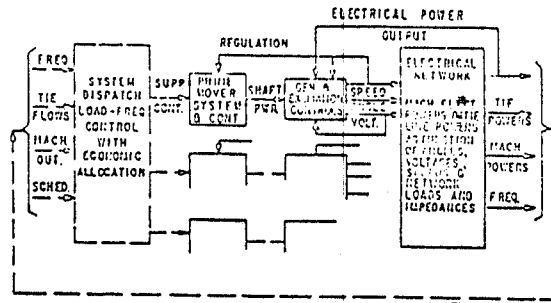

Figure 2. Schematic of Power System and Controls

There are many categories of problems which require emphasis on one or the other side of this interface. For instance, in electrical machine and network transients lasting a few seconds, the detail of the network, loads and machines is paramount, while variations in shaft power play a minor part. Simplifications in representation of the mechanical system are justified in such cases. On the other hand, where effects of significance are system frequency and interchange control lasting more than a minute, the amount of detail of the network can be reduced while the representation of the prime-mover/energy supply systems becomes paramount.

Obviously, the degree of detail of representation and the simplifying assumptions that can be made are a function of the particular problem. This fact places a great deal of importance on a grasp of the over-all process physics and a thorough understanding of the fundamentals.

Sometimes the interface between the areas which can be grossly simplified and others which must be detailed can shift considerably. Examples involve problems of subsynchronous resonance interactions with mechanical shaft natural frequencies; fast valving for transient stability; load rejection transients where prime mover overfrequency is an important effect; disturbances resulting in severe generation/load imbalances where the effects of significance may develop over many seconds.

Although the term "Power System Dynamics" can encompass a tremendous range of problems and effects, there has been a tendency to associate these problems with the phenomena of "Power System Stability," usually related to the question of whether or not a system remains in synchronism after a credible disturbance. The answer to such a question has usually involved simulations of one or two seconds in the normal system. The more difficult situations, however, involve stability problems that are less conventional and are characterized by phenomena that develop over several seconds. In these cases, load

characteristics, excitation controls and prime mover characteristics are particularly significant. Often, even if instability does develop the question does not end there but rather one must ascertain system behavior following the loss of synchronism of one of its parts in order to properly design protective schemes which will ensure the survival of the majority of the system as well as minimize hazards to equipment. The point must, therefore, be made that "Power System Dynamics" is not merely "transient stability." Some of the major engineering aspects involving power system dynamics can require highly complex analysis of system behavior. In these cases it is very important to (1) use relevant process models, (2) use computational tools tailored to the task, and (3) properly interpret the results.

MODELING DETAIL

The variations in process modeling that can be used depending on the phenomena of dominant importance are many.^{1,2} We shall make our point by showing variations on modeling detail on the part dealing merely with generators and networks, recognizing that a wide range of modeling alternatives can also apply to phenomena involving other elements of the power system; namely, loads, excitation systems and prime mover systems.

Figures 3 to 10 summarize aspects of modeling detail involving machine and network. Figure 3 starts with the simple problem of a single phase alternating ideal voltage source connected to a linear network made up of resistance, inductance and capacitance elements. Figure 4 extends this problem to the 3-phase situation, still preserving the network as describable by linear differential equations and the source as ideal voltage sources.

Figure 5 evolves from the case of Figure 4 to include nonlinearities such as caused by saturation of magnetic elements. Here the solution techniques which use components are no longer applicable since superposition is not valid in nonlinear systems.

Figure 6 expands the detail with the representation of the generator by differential equations in the d and q axes accounting for the transients in rotor and armature currents and their effect on voltage producing fluxes. Figure 6 represents the maximum of detail in both machine and network. Such effects as subsynchronous resonance, harmonics generated by saturation can be studied with this representation.

Figure 7 shows the next step wherein the network equations are reduced to solution of the fundamental frequency effects. This represents reduction of the network differential equations to algebraic equations solving for the fundamental frequency voltages and currents while preserving the time varying (differential equation) nature of fluxes and rotor speed giving rise to varying magnitude and frequency of generated voltages. Frequency effects on network impedances are included.

Figure 8 follows from the model of Fig. 7 by neglecting the effect of frequency variations in the generated voltages and in the network parameters. This is the degree of detail generally used in stability studies where machine rotor flux behavior must be accounted for both for their effect on synchronizing and damping torques.

Figures 9 and 10 show successive simplifications of the machine model with removal of the rotor flux differential equations and representation of source voltages as constant values behind constant reactances. Figure 10 uses the classical representation of constant voltage behind a transient reactance symmetrical in both axes.

These are merely examples of the wide range of modeling detail that can enter into a particular problem solution. The choice of the adequate model for the problem in question requires intimate knowledge of fundamentals and orders of magnitude of effects.

Source	Network	Nature of Results	Applications & Limitations	Solution Methods and Tools
Ideal sinusoidal source behind constant inductance with constant or varying frequency, single phase.	R, L, C linear elements - treated by differential equations.	Instantaneous time solution of voltages and currents.	Switching surges, recovery voltages. Applicable to linear single phase systems or to symmetrical 3Ø systems where transients do not involve imbalances.	TNA, analog computer. Digital computer (with traveling wave or lumped parameter solution methods). Digital differential analyzer.

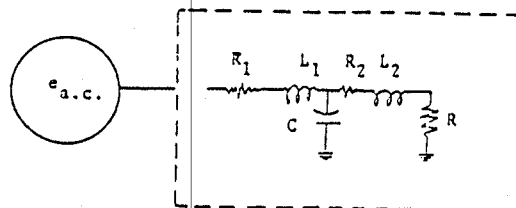

Figure 3

Source	Network	Nature of Results	Applications & Limitations	Solution Methods and Tools
Ideal sinusoidal balanced 3 ϕ sources behind constant inductances in each phase with constant or varying frequency (source inductance usually represented by X_c'').	R,L,C linear elements - treated by differential equations of 3 phases or differential equations of α , β and 0 networks.	Instantaneous time solution of phase voltages and currents and/or α , β 0 components.	Switching surges, recovery voltages, short circuits. Applicable to linear 3 ϕ systems with or without imbalances. Duration of transients short relative to flux decay time constants of generators.	TNA, analog computer. Digital computer (with traveling wave or lumped parameter solution methods). Digital Differential Analyzer.

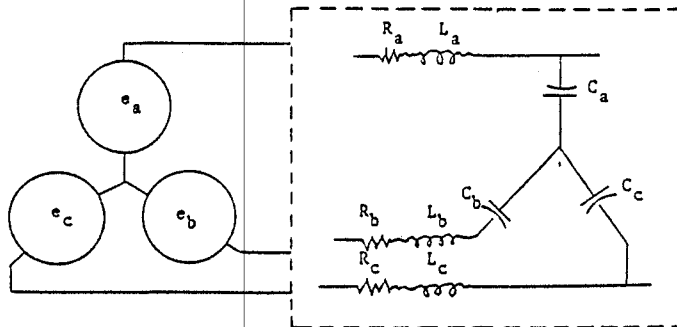

Figure 4

Source	Network	Nature of Results	Applications & Limitations	Solution Methods and Tools
Ideal sinusoidal balanced 3 ϕ sources behind constant inductances in each phase with constant or varying frequency (source inductance usually represented by X_d'').	R,L,C elements with nonlinear characteristics (magnetic saturation, thyrite resistors, etc.) differential equations of 3 phases.	Instantaneous time solution of phase voltages and currents.	Switching surges, recovery voltages, energization transients, short circuits. Applicable to nonlinear 3 ϕ systems with or without imbalances. Duration of transients short relative to flux decay time constants of generators.	TNA, analog computer. Digital computer (with traveling wave or lumped parameter solution methods). Digital differential analyzer.

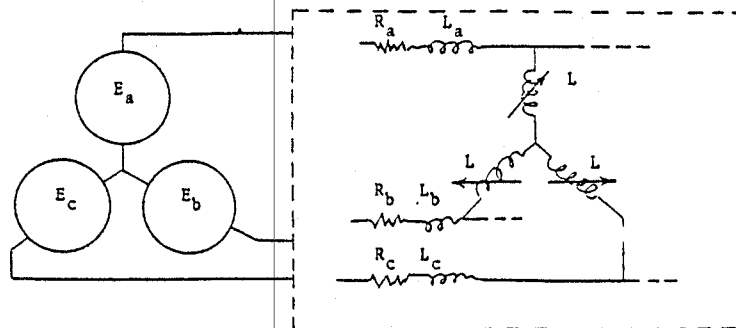

Figure 5

Source	Network	Nature of Results	Application & Limitations	Solution Methods and Tools
Source represented by equations of flux behavior in d and q axes. Instantaneous terminal phase voltages derived from d,q,o transformation.	R,L,C elements with nonlinear characteristics (magnetic saturation, thyrite resistors, etc.) described by differential equations.	Instantaneous time solution of phase voltages, currents, powers, etc.	Switching surges, recovery voltages, energization transients, subsynchronous resonances, short circuits, load rejection transients. Applicable to nonlinear 3 ϕ systems with or without imbalances. Solution takes into account generator flux effects and is valid for short or long durations.	Analog computer (limited scope problem). Digital computer, scaled model of machines and network.

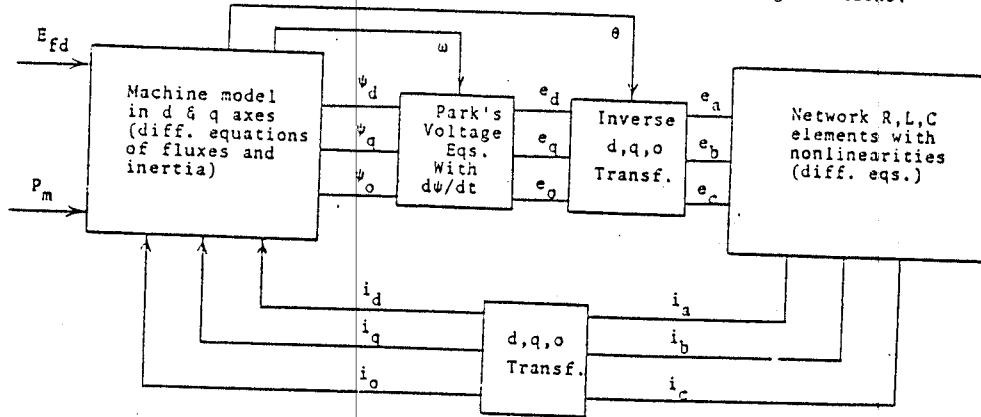

Figure 6

Source	Network	Nature of Results	Applications & Limitations	Solution Methods and Tools
Source represented by equations of flux behavior in d and q axes. Terminal voltage obtained as fundamental frequency positive sequence phasor by multiplying flux with speed. Armature and network transients neglected.	Z(j ω), Y(j ω) elements with nonlinear characteristics and frequency dependence. Network equations described by complex algebraic equations.	Fundamental frequency solutions of phase voltages and currents expressed as phasors. Machine angles, powers, etc.	Fundamental frequency transients following load rejections or other balanced network disturbances where frequency effects are significant. Applicable to balanced 3 ϕ systems for fundamental frequency effects over several seconds.	Analog computer (small size problem). Digital computer. Scaled models of machines and network.

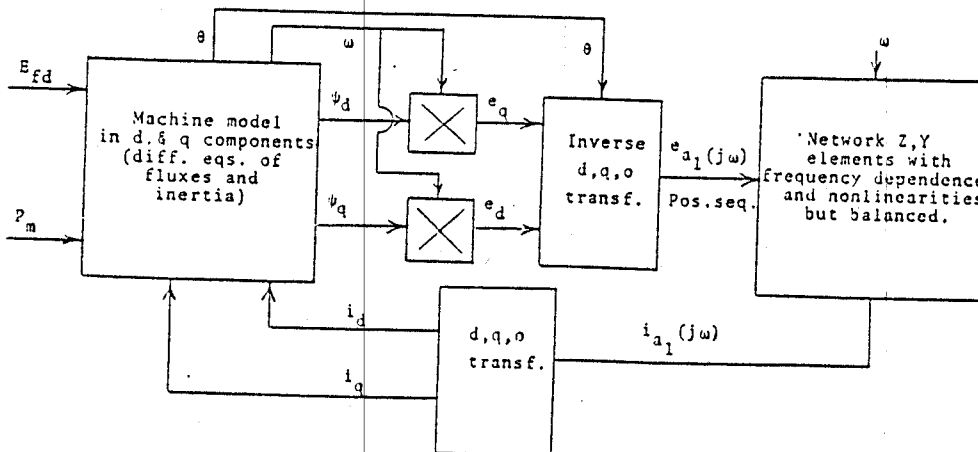

Figure 7

Source	Network	Nature of Results	Applications & Limitations	Solution Methods and Tools
Source representation same as in Fig. 7 except voltage taken equal to flux (speed assumed rated).	$Z(j\omega)$, $Y(j\omega_0)$ elements with or without nonlinear elements. Network equations described by complex algebraic equations. Negative and zero sequence network includes machine.	Fundamental frequency solutions of positive sequence voltages and currents as phasors. Machine angles, speeds, powers (average). (Negative and 0 sequence quantities can also be obtained).	Fundamental frequency transients following faults or other disturbances. Machine rotor angles, powers. Applicable to 3 ϕ systems for fundamental frequency effects over several seconds. Stability phenomena.	Analog computer (small size problem). Digital computer. Scaled models of machines and network. Hybrid computers.

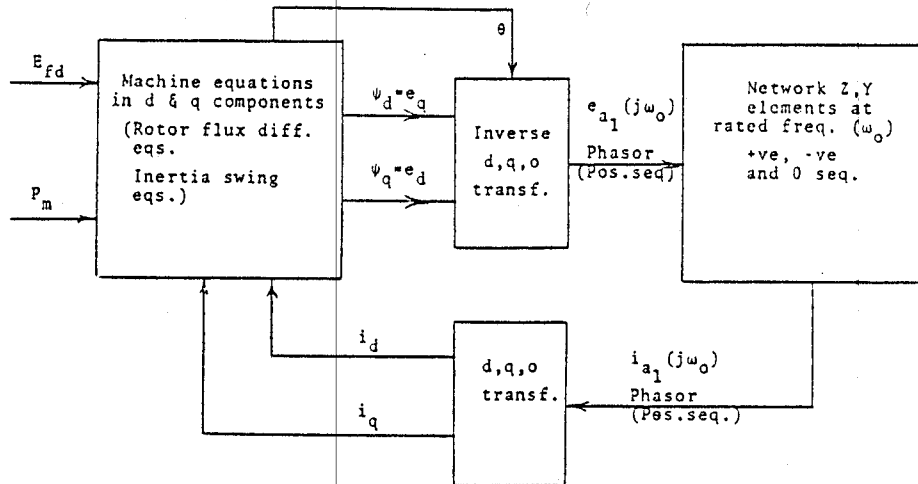

Figure 8

Source	Network	Nature of Results	Applications & Limitations	Solution Methods and Tools
Source represented as constant voltages behind appropriate reactances in d and q axes. * can be subtransient, transient, or steady-state (synchronous) depending on problem. Machine saliency included.	$Z(j\omega)$, $Y(j\omega_0)$ elements with or without nonlinear elements. Network equation: described by complex algebraic equations. Negative and zero sequence network includes machine.	Fundamental frequency solutions of sequence currents and voltages. If machine swing equations are included, rotor angle transients are obtained (stability)	Fundamental frequency network conditions. Symmetrical short circuit currents (balanced and unbalanced). With proper choice of machine reactances, may be used for stability calculations. Applicable to 3 ϕ systems for fundamental frequency effects. Used generally for conditions at some instant in time depending on value of source reactance and voltage used. If swing equations are solved (stability) transient reactance values are used and solution approximates conditions in first half second.	Digital computer

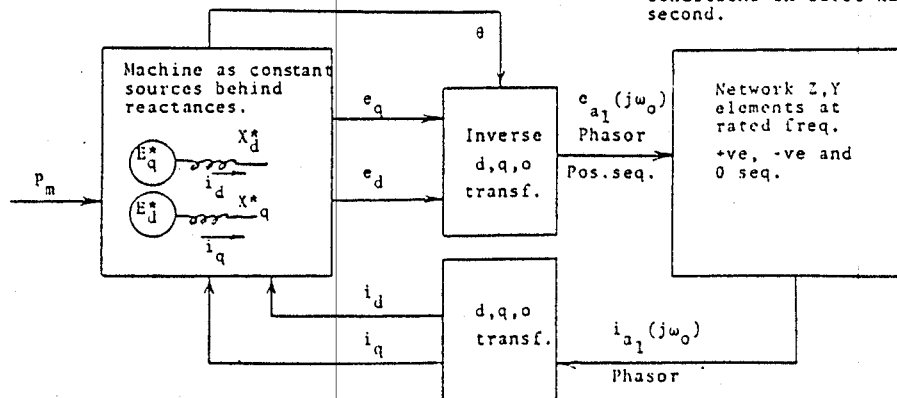

Figure 9

Source	Network	Nature of Results	Applications & Limitations	Solution Methods and Tools
Source represented as constant voltage behind an equivalent reactance. Machine saliency neglected.	$Z(j\omega_0)$, $Y(j\omega_0)$ elements with or without nonlinear elements. Network equations described by complex algebraic equation. Negative and zero sequence network includes machine.	Fundamental frequency solutions of sequence currents and voltages. If machine swing equations are included, rotor angle transients are obtained (stability-classical solution).	Applicable for short circuit studies (balanced and unbalanced) and first swing stability studies.	A-C network analyzer. Digital computer.

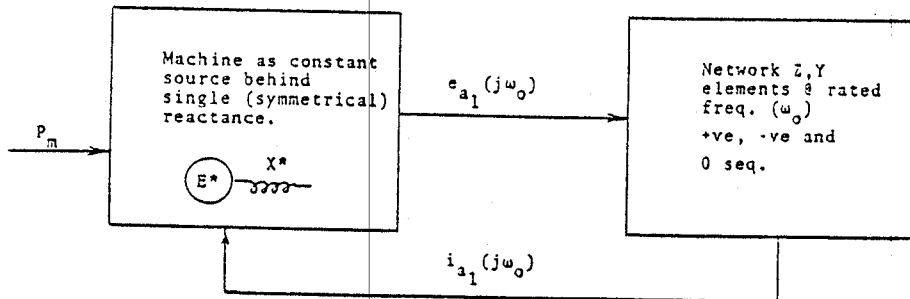

Figure 10

LOAD CHARACTERISTICS^{3,6}

The sensitivity of results to load characteristics increases markedly in cases where the design of the power system is dictated by stability considerations. In many situations stability may not be governing. Location of loads and generation often results in extremely stiff systems where stability could only present a problem for rather severe disturbance criteria such as a 3 ϕ fault for 10 cycles. In such systems which essentially exhibit minor variations in voltage during realistic disturbances, accuracy of load representation may be relatively unimportant.

On the other hand, in systems where transmission design is pushed to limits dictated by stability, the dynamic behavior of loads becomes as significant as the disturbance criteria (severity and duration of fault).

Figure 11 illustrates the sensitivity of certain results to assumptions on load characteristics. The curves show the frequency behavior of a load area supplied by a significant amount of remote generation following the loss of this remote regeneration. Figure 11 shows how assumptions of load characteristics can alter the results of frequency behavior for this occurrence. With more than 75% of the real part of the load assumed to vary directly with voltage, the net result is a collapse in system voltage and a drastic reduction in con-

nected load resulting in an eventual rise in system frequency rather than an expected drop in frequency.

When realistic load characteristics are modeled, with a certain percentage made up of induction motor loads, even more surprising results can develop. The induction motor load can exhibit an effective admittance about 4 to 5 times normal depending on the extent and duration of a voltage dip which could cause motors to stall. This is another stability type phenomenon where results are radically different depending on whether or not the disturbance was severe enough to cause motor stalling. Conceptually, one could think of the case as involving a single event, as the initial disturbance or a sequence of events where the initial disturbance is rapidly followed by another involving a drastic increase in load admittance. The point is that the transition from one case to the other is so abrupt and leads to so widely differing results that system designers experiencing conditions on the optimistic side of the chasm may be lulled into a sense of security which could be drastically altered by a minor change in load assumptions.

Modeling of load characteristics remains one of the most important aspects of power system dynamics, deserving a great deal more attention and research than has been devoted by the industry to date.

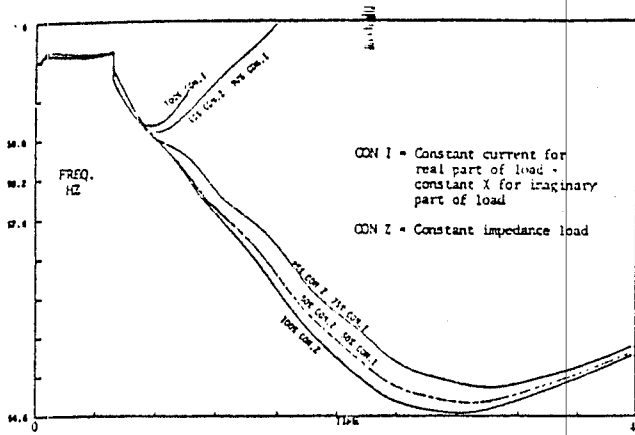

Figure 11. Frequency Variation Following Loss of Remote Generation

INTERPRETATION OF RESULTS

The interpretation of stability performance from simulation results of machine angle swing curves is at times difficult, especially in cases where the problem of instability develops beyond the first swing.

A discussion of some typical effects as revealed in stability swing curves follows:

1. First Swing Stability

The most clear-cut manifestation of instability is the pulling out of step in the first swing (Fig. 12).

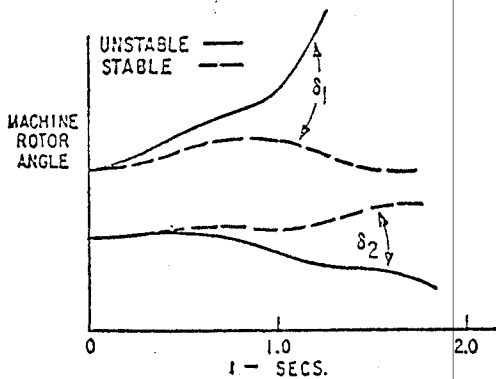

Figure 12. Machine Rotor Angle Transients Following Electrical Fault

2. Instability Following the First Swing

Several phenomena which might cause instability or what appears to be instability on subsequent swings are:

(a) Lack of damping of machine oscillations caused primarily by weak transmission and aggravated by voltage regulator action. Certain system conditions can exist which produce negative damping in machines even without action from voltage regulators.⁵ This happens particularly in situations where a large load is served mainly by remote generation, with the local generation being a relatively small portion compared with the remote generation. The damping of the local generation can be negative in such cases. Figure 13 shows the case of undamped oscillations typical of such dynamic instability cases. It must be emphasized that the condition is a function of the state of the system following the disturbance rather than the transient shock of the disturbance itself. In other words, if the end state is obtained with the switching of a line, the instability characterized with build-up of oscillations will occur regardless of whether the switching of the line was preceded by a line fault. The shock of the fault would merely cause the oscillations to grow from larger initial amplitudes.

Dynamic instability can result in oscillations growing to a magnitude where eventual pull-out results. Sometimes the oscillations will grow to a certain magnitude and then sustain themselves at that magnitude. This can occur where the lack of damping is produced by voltage regulator action. As oscillations increase, the regulators and exciters begin to hit limits and ceilings and the effective gain of these devices is decreased. These situations result in so-called, limit cycles. Although in these cases pull-out and loss of synchronism may not occur, the performance of the power system is intolerable.

(1) This does not account for the system's initial conditions. The system's initial conditions are important. The system's initial conditions are important. The system's initial conditions are important.

(2) Does the necessary angle change in power flow?

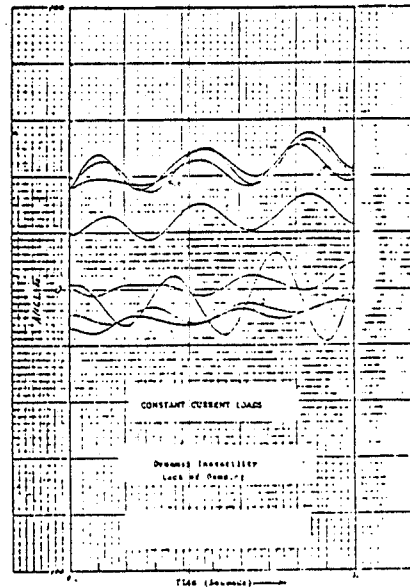

Figure 13

(b) In some instances, several modes of oscillation are excited by the disturbance such that, at some point beyond the first swing, a superposition of modes results in larger angle deviations and eventual pull-out of one or more plants. The loss of synchronizing power leading to pull-out is due to an excessive angle excursion reached some time after the first swing through an amplification effect due to superposition of modes. Figure 14 shows an example of this phenomenon. In this case, the disturbance was a 30 fault followed by the switching of a line section. Figure 15 shows that a less severe fault (20 ground fault), followed by the same switching operation results in stable conditions as the amplitude of subsequent angle swings did not reach the point where loss of synchronizing power occurs. This is in contrast to the phenomenon of lack of damping explained in (a) above where the phenomenon is a sustained growth in amplitude of individual modes of oscillations leading to eventual loss of synchronism or to a sustained state of oscillations, the magnitude of the disturbance affecting only the length of time before the oscillations reach a certain level or before pull-out occurs. In comparing Figure 15 with Figure 14, it should be noted that the time scales are different on the two sets of figures.

The phenomenon of amplification of angle excursions beyond the first swing through superposition of different modes is obviously aggravated by poor damping of these modes, since if good damping exists, the amplitudes of the individual modes would be well reduced beyond the first swing.

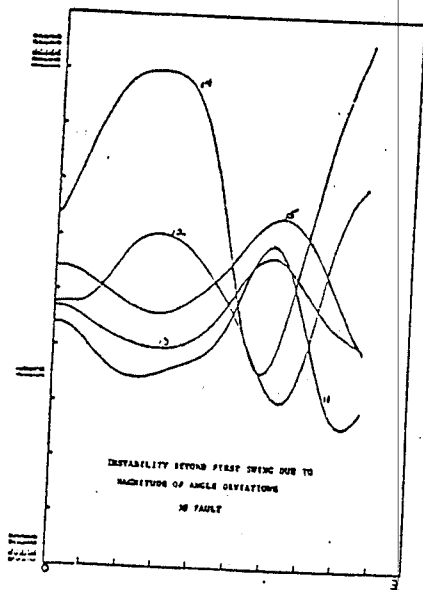

Figure 14

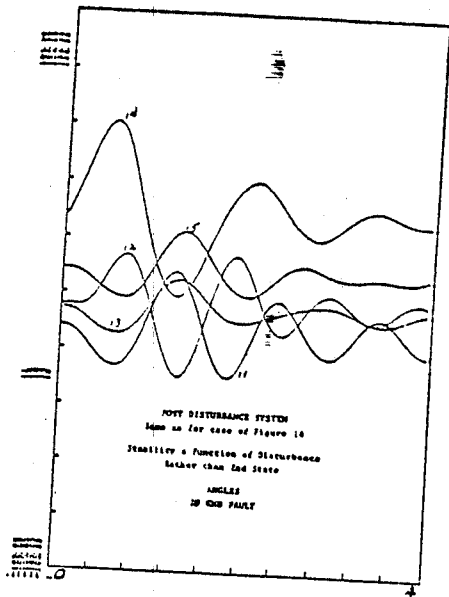

Figure 15

(c) The superposition of modes discussed in (b) above can also give rise to what appears to be dynamic instability discussed in (a). Here, although the amplitude of the oscillations are initially not large enough to exhibit the nonlinear characteristics associated with the phenomenon of loss of synchronism, they appear to grow in amplitude. If the simulation run is terminated too soon, the real nature of the phenomena may not be revealed. Figure 16 shows this type of effect which is a "beat" phenomenon.

Evidently, where these cases occur, the system has marginal damping since for beats to be evident the modes of oscillation must last a long time.

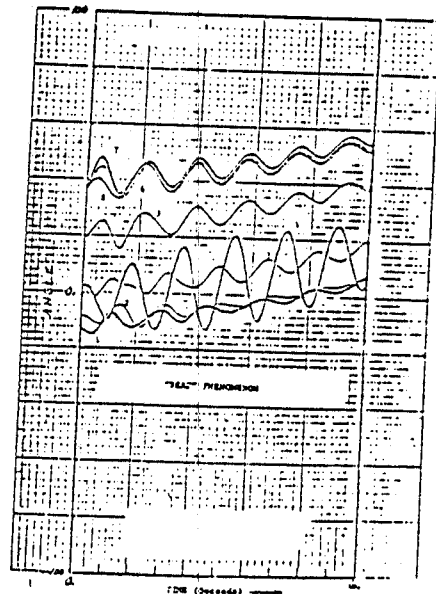

Figure 16

3. Sensitivity of Results

Whenever marginal stability cases are noted, exhibiting any of the phenomena discussed above, it is appropriate to establish the sensitivity of the results to various factors and assumptions. A marginally stable situation, especially where the instability phenomena are caused by poor or negative damping, is one that must be avoided by measures which establish a very decided degree of stability.

Figure 17 can be compared with Figure 13 to show the effects of the assumption on load characteristics (constant current for the real part for Figure 13 versus constant impedance for Figure 17) for a particular situation.

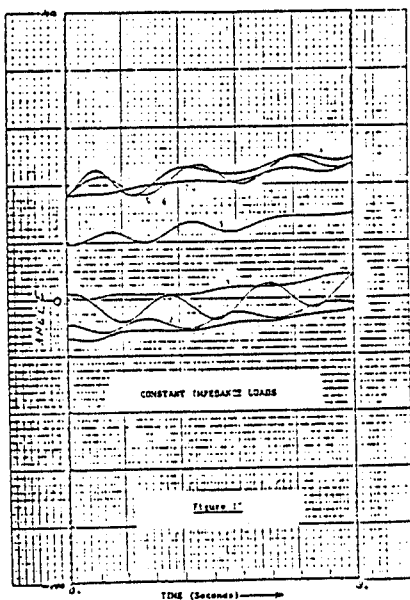

Figure 17

A poorly damped system although theoretically stable by mathematical definition, may be unacceptable from a system performance point of view. Random disturbances can keep the system in constant oscillations which at the frequency of about 1 Hz are intolerable to industrial and residential customers.

The top curves of Figure 13 show the swing performance of a large interconnected system following a severe disturbance. The bottom set of curves corresponds to the identical disturbance except that here the generators were simulated with modern static excitation systems and stabilizers. This is an emphatic demonstration of the potential benefits that can be derived from excitation systems designed to provide damping.

Evaluation of damping effects imposes increased demands on detail of modeling of synchronous machines, excitation systems and prime mover systems.

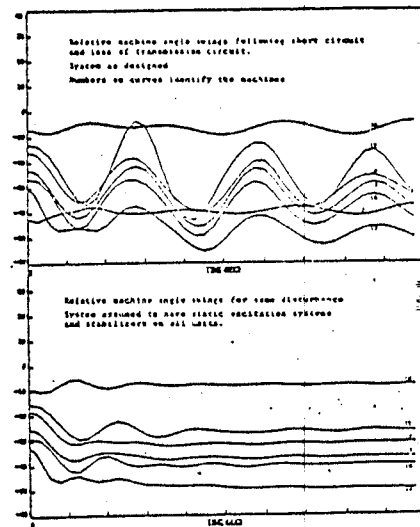

Figure 18

NEW TRENDS IN SOLUTION METHODS

Exploration of power system dynamic effects is critically a function of the ability of engineers to predict by simulation the behavior of systems. The less this ability the more conservative must be the design criteria and the greater must be the margins imbedded into designs. Most of the discussions on effects to be considered in power system dynamics become academic unless engineering solution methods are available to yield results within the constraints of time, cost and human endurance which are part of every real-life situation. The subject of new techniques in solution of power system problems, therefore, assumes major importance. ⁸

The digital computer has probably had far more impact on the technical and economic affairs of mankind than any single invention in the last 100 years. But, like most inventions, it has gone through a very rapid evolution as have our concepts of its logical applications. The rate of evolution has increased manyfold in the last few years, and the management of computer resources has become a major factor in the realization of large engineering projects.

In order to appreciate the factors involved, let us review briefly the evolution of computation and the recent new directions that it is taking.

In the 1950's, for example, when large-scale computers were seeing their first real boom, the extremely high cost of hardware and the awesome complexity of the computer/engineer interface led to almost total centralization of computer functions and bred a whole new generation of professional "interpreters," computer centers, programming departments, etc. Since the early 1950's, the pace of computer evolution has been staggering, and those working close to this field have grown used to seeing changes in size, speed, efficiency, etc. of orders of magnitude in just a few years. The development of high-level software permitting direct engineer/computer

communication has also been extremely significant. The initial growth was entirely in the direction of size and speed, but in the late 1960's several manufacturers began to "think small." The result was the first mini-computers and an even more accelerated progress in performance.

By almost any standard of measurement, computational costs have come down by a factor of 10 in just the last four years, and the trend is still downward. But, in addition to this, economies of scale in computers have disappeared for many applications.

With hardware costs becoming less significant, over-all costs are influenced by those features that permit increase in human efficiency. It matters little how fast and cheaply a load flow is performed if access to results is obtained with a day's time lapse instead of minutes.

With this in mind, it is apparent that computers should be as closely coupled to the person or function they serve as possible. Time-sharing was a significant step in this direction. The applications of autonomous dedicated computers is another.

A mini-computer today has the speed of the most advanced modern large computers and a memory size comparable to large machines of only a few years back.

Concurrently, a revolution has taken place in computer software. Whereas communication with computers used to require special machine language and the employment of specialized staff in such languages, today computer languages are easy to use and known by every new graduate engineer. Direct communication between engineer and computer is a mode of operation which is becoming increasingly popular.

This factor of eliminating a now superfluous human link between the engineer and the computer is probably as significant as the elimination of turn-around time through the use of dedicated interactive facilities.

Figure 19 shows the composition of a dedicated computer facility especially fitted with a complete set of interactive power system analysis programs. Interactive programs are designed so that engineers can examine results as the run progresses, make changes and adjustments, and essentially treat the problems as one would on an AC network analyzer or analog computer where there is a direct coupling without appreciable delay between the engineer's question and the analyzer or computer's answer. By having the ability to converse through a keyboard CRT and to examine the results on the screen, rapid experimentation can be made and the results outputted on hard copy only when a valid solution needs to be documented. In addition to printed output, an X-Y plotter provides means of presenting plotted results, such as are frequently needed in load flow studies and for the interpretation of dynamic simulation results.

The capacity of the interactive power system analysis programs handled by the mini-computer facility is quite large. Five hundred bus load flow problems, dynamic simulations of power systems with 50 generators and 250 buses including excitation and governor control effects are currently being executed with such speed that the bottleneck is now the ability of the engineer to digest the results. The dedicated facility is also used in the same role as a general-purpose analog computer for the solution of dynamic problems, such as analysis of excitation and governor controls, plant hydraulic hydraulic transients, etc.

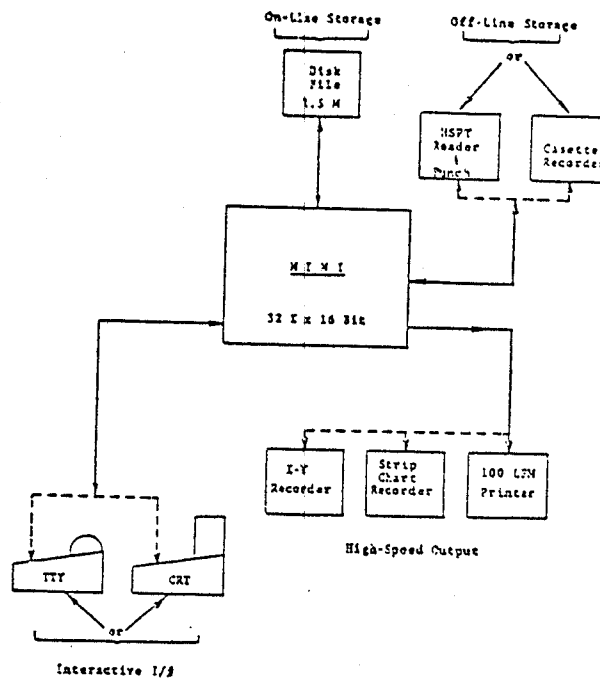

Figure 19
Dedicated Interactive Computer System for Power System Analysis

CONCLUSIONS

The technological challenges of supplying the demands for electric energy in the present and foreseeable future require planning and design effort of scope and complexity unmatched in other industries.

Much of the complexity arises from the fact that in widespread interconnected systems analysis of any segment of the system additions must consider effects throughout the whole interconnected system. This is particularly the case where the size of each system addition is a significant fraction of the over-all system as is happening in developing nations.

The schedules inherent in much of this engineering work, often aggravated by surprises in equipment availability, load growth, and other unforeseen factors, has placed a very high premium on the speed and accuracy of solutions.

In presenting an overview of the subject of power system dynamics, we have had the opportunity of accentuating aspects which we believe are of major importance.

These aspects involve:

(1) Thorough understanding of the fundamentals, which is essential for the choice of the right model for the problem at hand, and for the interpretation of results.

(2) Accuracy of load modeling, especially in system configurations where stability is a governing criterion.

(3) The key requirement of providing computational tools designed for the task of dynamic analysis where interactive computation and rapid access to results is essential.

REFERENCES

1. F. P. de Mello, "Process Dynamics in Electric Utility Systems," ISA Paper 505-70, International Conference Exhibit of ISA, October 26-29, 1970, Philadelphia, Pa.
2. F. P. de Mello, "Modern Concepts of Power System Dynamics - The Effects of Control," IEEE Tutorial Publication 70M62-PWR, May, 1970, pp. 25-40.
3. F. G. McCrackin and W. R. Schmus, "Modern Concepts of Power System Dynamics - The Representation of System Load in Stability Studies," IEEE Tutorial Publication 70M62-PWR, May 1970, pp. 41-46.
4. F. P. de Mello and C. Concordia, "Concepts of Synchronous Machine Stability as Affected by Excitation Control," IEEE Transactions on Power Apparatus & Systems, PAS-88, pp. 516-529, April, 1969.
5. F. P. de Mello and T. F. Laskowski, "Concepts of Power System Dynamic Stability," IEEE paper to be presented at the Joint Power Generation Conference, Miami, September, 1974.
6. W. Mauricio and S. Semlyen, "Effect of Load Characteristics on the Dynamic Stability of Power Systems," IEEE Transactions on PAS, 1972, pp. 2295-2304.
7. "System Load Dynamics Simulation Effects and Determination of Load Constants," prepared by Computer Analysis of Power Systems Working Group of the Analytical Methods Subcommittee, PAS March/April, 1973, Vol. PAS-92.
8. J. M. Undrill, F. P. de Mello, T. E. Kostyniak and R. J. Mills, "Interactive Computation in Power System Analysis," Proceedings of IEEE, Special issue on Computation in the Power Industry, July, 1974.