

# Multi-machine Systems

## 1.0 Introduction and assumptions

We have so far studied the one-machine-infinite bus and the two-machine system. Now we extend analysis to a multi-machine system. We will revisit this topic later in the course when we have more fully developed the synchronous machine model.

Section 2.9 provides 5 assumptions, four of which amount to use of the classical machine model ( $P_m$  is constant, no damping, constant internal voltage magnitude, and mechanical rotor angle coincides with angle of internal voltage).

We will relive the assumption of no damping. Therefore our swing equation (with per-unit power) will appear as:

$$\frac{2H}{\omega_{Re}} \dot{\omega}(t) = P_m - P_e - D\omega \quad (1)$$

A conservative estimate for damping frequently used in industry is  $D=2.0$  when power is in per-unit.

Another assumption is that all loads are represented by passive impedances, i.e., all load is assumed to be constant impedance load. This is not accurate because loads respond to voltage and frequency deviation in a variety of ways that impedances do not capture. In general, stability performance is improved with constant impedance loads because the power decreases as voltage declines with the square of the voltage. Therefore, representing loads as constant impedance results in optimistic results (stability limits, for example, will be identified higher than they should be).

Use of the constant impedance load model allows us to catch a first glimpse into what a full-blown stability program looks like, with relatively little work, and so we will use it temporarily.

## **2.0 Accounting for the network**

We will have a swing equation for every machine in the network, i.e., for machine  $i$ , we will have

$$\frac{2H_i}{\omega_{Re}} \dot{\omega}_i(t) = P_{mi} - P_{ei} - D_i \omega_i \quad (2)$$

We have previously accounted for the network effects in our one-machine-infinite-bus system by expressing

$$P_{ei} = \frac{EV}{X_k} \sin \delta, \quad k = 1, 2, 3 \quad (3)$$

where  $k=1,2,3$  denotes pre-fault, fault-on, and post-fault systems, respectively, and  $X_k$  is the transfer impedance between internal machine voltage and infinite bus.

For the simple networks considered so far, we have been able to easily determine  $X_k$ . It is not possible to do so for general networks, however, because they are typically large and complex, and because there is no infinite bus.

Now, we will need to utilize the real power flow equation, which is expressed by eq. (2.55) of your text as

$$P_{ei} = E_i^2 G_{ii} + \sum_{\substack{j=1 \\ j \neq i}} E_i E_j Y_{ij} \cos(\theta_{ij} - \delta_i + \delta_j) \quad (4)$$

where

$$G_{ii} = \text{Re}\{\bar{Y}_{ii}\}, \quad Y_{ij} = |\bar{Y}_{ij}|$$

and  $\bar{Y}_{ii}$  and  $\bar{Y}_{ij}$  are elements of the Y-bus matrix.

The Y-bus matrix needed here differs from the Y-bus matrix of the standard power flow model in three important ways:

1. Machine internal buses must be included
2. Loads must be represented as constant impedance instead of constant power
3. Change in network configuration for fault-on and post-fault conditions must be accounted for.

We will address each one of these changes in what follows.

## 2.1 Machine internal buses

Relative to the power flow model, we must form an extended network by inserting a new bus between E and  $X'_d$ . This is illustrated in Fig. 1 below.

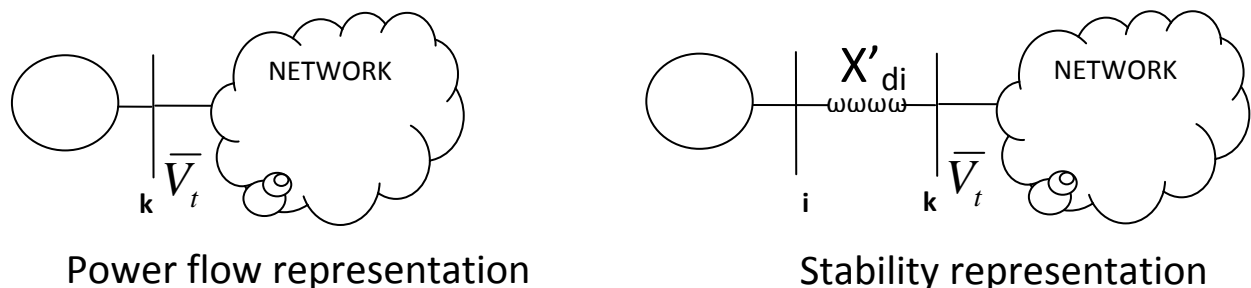

Fig. 1

So we must increase the Y-bus matrix dimension by 1 for each generator in the system. For every additional internal machine node  $i$  connected to existing terminal bus  $k$ , we will need to modify the Y-bus according to

- Add a new row and column for node  $i$  with diagonal element  $Y_{ii}=y_{ik}=-j/X'_{di}$  and off-diagonal elements all zero except for  $Y_{ik}=Y_{ki}=-y_{ik}=j/X'_{di}$  (here, upper case “Y” denotes Y-bus matrix element, and lower case “y” denotes admittance).
- Modify diagonal element  $Y_{kk}$  by adding to it  $y_{ik}=-j/X'_{di}$ .

The above modifications, when performed for all new generator nodes  $i$ , result in what we will call the *extended Y-bus matrix*.

## 2.2 Constant impedance loads

Loads are generally represented in the power flow model as constant power,  $P_L+jQ_L$ . We may convert such loads into constant impedance representation according to the following development:

$$P_L + jQ_L = V_L I_L^* \quad (\text{in pu}) \quad (5)$$

where  $I_L$  is the current flowing into the load. To obtain the equivalent admittance for this load, assuming constant voltage, we have

$$I_L = V_L Y_L \Rightarrow I_L^* = V_L^* Y_L^* \quad (6)$$

Substituting (6) into (5) results in

$$P_L + jQ_L = V_L V_L^* Y_L^* = |V_L|^2 Y_L^* \quad (7)$$

Solving for  $Y_L$  results in

$$Y_L = \frac{P_L + jQ_L}{|V_L|^2} \quad (8)$$

This is eq. (2.60) in your text. Recall the issue mentioned on page 2 above: under transient simulation, the voltage  $|V_L|$  is not constant, so the power drawn under voltage conditions that differ from the power flow voltage conditions will change, and this model enforces that the new power drawn will be proportional to the square of the voltage magnitude. We will accept this for now.

Now a question arises: Assume we have calculated  $Y_{Lk}$  for each load bus  $k$ . Which Y-bus elements are affected by inclusion of these admittances? Off diagonal or diagonal?

The answer is “diagonal” because the constant impedance loads are actually shunts from a bus to ground (accounted for only in diagonal Y-bus elements) and not from a bus to another bus (accounted for in both diagonal and off-diagonal elements).

### 2.3 Change in network configuration

Remember we will have at least three configurations to model: pre-fault, fault-on, and post-fault. To address this issue, we will form three different Y-bus matrices, denoted as:

- Pre-fault:  $Y_1$
- Fault-on:  $Y_2$
- Post-fault:  $Y_3$

where each  $Y_i$  includes the “load shunts” discussed in Section 2.2 above.

Let’s consider that there are  $n$  generator buses, numbered first, and  $r$  load buses, numbered last. Then the Y-bus relation can be written as

$$\begin{bmatrix} \underline{I}_n \\ \underline{I}_r \end{bmatrix} = \begin{bmatrix} \underline{Y}_{nn} & \underline{Y}_{nr} \\ \underline{Y}_{rn} & \underline{Y}_{rr} \end{bmatrix} \begin{bmatrix} \underline{V}_n \\ \underline{V}_r \end{bmatrix} \quad (9)$$

However, if the loads are modeled as shunts, then they are included in the Y-bus matrix, and their corresponding current injections should be 0. Therefore, (9) becomes:

$$\begin{bmatrix} \underline{I}_n \\ \underline{0} \end{bmatrix} = \begin{bmatrix} \underline{Y}_{nn} & \underline{Y}_{nr} \\ \underline{Y}_{rn} & \underline{Y}_{rr} \end{bmatrix} \begin{bmatrix} \underline{V}_n \\ \underline{V}_r \end{bmatrix} \quad (10)$$

Now we perform Kron reduction on load bus voltages  $\underline{V}_r$  from (10). First, multiple the bottom row by  $-\underline{Y}_{nr}\underline{Y}_{rr}^{-1}$ :

$$\begin{bmatrix} \underline{I}_n \\ \underline{0} \end{bmatrix} = \begin{bmatrix} \underline{Y}_{nn} & \underline{Y}_{nr} \\ -\underline{Y}_{nr}\underline{Y}_{rr}^{-1}\underline{Y}_{rn} & -\underline{Y}_{nr}\underline{Y}_{rr}^{-1}\underline{Y}_{rr} \end{bmatrix} \begin{bmatrix} \underline{V}_n \\ \underline{V}_r \end{bmatrix} \quad (11)$$

Note the term in row 2, column 2 is  $\underline{Y}_{nr}$ , so that

$$\begin{bmatrix} \underline{I}_n \\ \underline{0} \end{bmatrix} = \begin{bmatrix} \underline{Y}_{nn} & \underline{Y}_{nr} \\ -\underline{Y}_{nr}\underline{Y}_{rr}^{-1}\underline{Y}_{rn} & -\underline{Y}_{nr} \end{bmatrix} \begin{bmatrix} \underline{V}_n \\ \underline{V}_r \end{bmatrix} \quad (12)$$

Now add the second row to the first row to obtain:

$$\begin{bmatrix} \underline{I}_n \\ \underline{0} \end{bmatrix} = \begin{bmatrix} \underline{Y}_{nn} - \underline{Y}_{nr}\underline{Y}_{rr}^{-1}\underline{Y}_{rn} & \underline{0} \\ -\underline{Y}_{nr}\underline{Y}_{rr}^{-1}\underline{Y}_{rn} & -\underline{Y}_{nr} \end{bmatrix} \begin{bmatrix} \underline{V}_n \\ \underline{V}_r \end{bmatrix} \quad (13)$$

And we see that the first row provides an equation that is independent of the load bus voltages  $V_r$ , resulting in

$$\underline{I}_n = \left[ \underline{Y}_{nn} - \underline{Y}_{nr} \underline{Y}_{rr}^{-1} \underline{Y}_{rn} \right] \left[ \underline{V}_n \right] \quad (14)$$

This is eqt. (2.65) in your text. The implication of (14) is we have reduced the network to generator nodes only.

Now we introduce some additional Y-bus notation, where in all cases we assume we have already included  $X'_d$  to obtain the extended Y-bus.

Notation	Condition	Reduction	Load shunts?
$\underline{Y}_1''$	Pre-fault	Unreduced	Without
$\underline{Y}_1'$	Pre-fault	Unreduced	With
$\underline{Y}_1$	Pre-fault	Reduced	With
$\underline{Y}_2'$	Fault-on	Unreduced	With
$\underline{Y}_2$	Fault-on	Reduced	With
$\underline{Y}_3'$	Post-fault	Unreduced	With
$\underline{Y}_3$	Post-fault	Reduced	With

There are seven basic steps to perform in preparing to run a stability simulation. We will show these steps using a simple example, illustrated in Fig. 2. Notice that  $y_f$  and  $y_g$  are load shunts, and buses 1 and 5 are internal machine nodes.

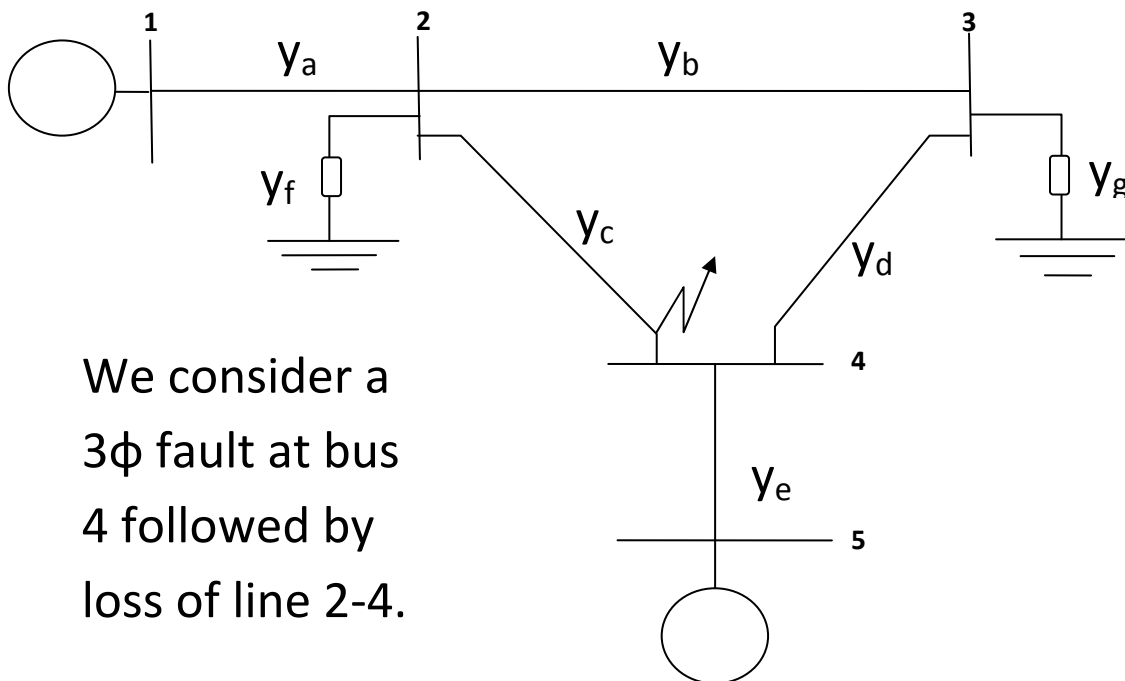

We consider a 3 $\phi$  fault at bus 4 followed by loss of line 2-4.

Fig. 2

We begin from  $\underline{Y}_1''$ , the pre-fault, unreduced Y-bus without load shunts.

1. Include load shunts:

$$\underline{Y}_1' = \underline{Y}_1'' + Y_L$$

where  $\underline{Y}_L$  contains  $Y_{Li}$  in the diagonal element corresponding to load bus  $i$ .

$$\underline{Y}'_1 = \underline{Y}''_1 + Y_L = \begin{bmatrix} Y_{11} & Y_{12} & Y_{13} & Y_{14} & Y_{15} \\ Y_{21} & Y_{22} & Y_{23} & Y_{24} & Y_{25} \\ Y_{31} & Y_{32} & Y_{33} & Y_{34} & Y_{35} \\ Y_{41} & Y_{42} & Y_{43} & Y_{44} & Y_{44} \\ Y_{51} & Y_{52} & Y_{53} & Y_{54} & Y_{55} \end{bmatrix}$$

$$= \begin{bmatrix} y_a & -y_a & 0 & 0 & 0 \\ -y_a & y_a + y_b + y_c & -y_b & -y_c & 0 \\ 0 & -y_b & y_b + y_d & -y_d & 0 \\ 0 & -y_c & -y_d & y_c + y_d + y_e & -y_e \\ 0 & 0 & 0 & -y_e & y_e \end{bmatrix} + \begin{bmatrix} 0 & 0 & 0 & 0 & 0 \\ 0 & y_f & 0 & 0 & 0 \\ 0 & 0 & y_g & 0 & 0 \\ 0 & 0 & 0 & 0 & 0 \\ 0 & 0 & 0 & 0 & 0 \end{bmatrix}$$

$$= \begin{bmatrix} y_a & -y_a & 0 & 0 & 0 \\ -y_a & y_a + y_b + y_c + y_f & -y_b & -y_c & 0 \\ 0 & -y_b & y_b + y_d + y_g & -y_d & 0 \\ 0 & -y_c & -y_d & y_c + y_d + y_e & -y_e \\ 0 & 0 & 0 & -y_e & y_e \end{bmatrix}$$

Note that we could Reduce  $\underline{Y}'_1$  to obtain  $\underline{Y}_1$  at this point, but this is unnecessary if the fault is applied at  $t=0$ . We will skip this step here.

2. Modify  $\underline{Y}'_1$  to obtain  $\underline{Y}'_2$ , the fault-on Y-bus. Note that you should NOT obtain  $\underline{Y}'_2$  from  $\underline{Y}_1$  (the reduced network) since  $\underline{Y}_1$  may not include the faulted bus.

To see how to do this, let's consider a simpler case of faulting bus 2 in the two-bus system of Fig. 3.

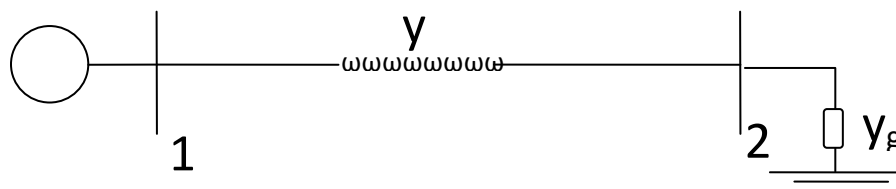

Fig. 3

The corresponding Y-bus relation is

$$\begin{bmatrix} I_1 \\ 0 \end{bmatrix} = \begin{bmatrix} y & -y \\ -y & y + y_g \end{bmatrix} \begin{bmatrix} V_1 \\ V_2 \end{bmatrix}$$

The fault at bus 2 causes  $V_2=0$ . Therefore the first equation becomes  $I_1=yV_1$ . How did we obtain this? We

- zeroed the voltage variable corresponding to the faulted bus,  $V_2$ ;
- removed the second column of Y-bus

- removed the current injection equation corresponding to the faulted bus (because this bus has been merged with the ground node);

Since we have faulted bus 4 in our small network, we remove the fourth column and the fourth equation, to obtain

$$\underline{Y}'_2 = \begin{bmatrix} y_a & -y_a & 0 & 0 \\ -y_a & y_a + y_b + y_c + y_f & -y_b & 0 \\ 0 & -y_b & y_b + y_d + y_g & 0 \\ 0 & 0 & 0 & y_e \end{bmatrix}$$

3. To obtain  $\underline{Y}_2$ , we perform Kron reduction on  $\underline{Y}'_2$  to eliminate buses 2, and 3, leaving only buses 1 and 5. We will skip this step here as it is a bit messy using just symbols.

4. To obtain  $\underline{Y}'_3$ , we should start from  $\underline{Y}'_1$

- Not  $\underline{Y}_1$  because  $\underline{Y}_1$  is reduced and may not have the buses in it terminating the outaged circuit;
- Not  $\underline{Y}'_2$  because the fault is cleared and the faulted bus is no longer at zero voltage.

In our case, the outaged circuit is circuit 2-4. To obtain  $\underline{Y}'_3$ , let's define a circuit outage modification matrix  $Y_{jk}$  containing terms corresponding to the changes to  $\underline{Y}'_1$  that are necessary. In the case of our example, this will be  $\underline{Y}_{24}=\underline{Y}_{42}$ , given by

$$\underline{Y}_{24} = \begin{bmatrix} 0 & 0 & 0 & 0 & 0 \\ 0 & y_c & 0 & -y_c & 0 \\ 0 & 0 & 0 & 0 & 0 \\ 0 & -y_c & 0 & y_c & 0 \\ 0 & 0 & 0 & 0 & 0 \end{bmatrix}$$

Then

$$\underline{Y}'_3 = \underline{Y}'_1 - \underline{Y}_{24}$$

$$= \begin{bmatrix} y_a & -y_a & 0 & 0 & 0 \\ -y_a & y_a + y_b + y_c + y_f & -y_b & -y_c & 0 \\ 0 & -y_b & y_b + y_d + y_g & -y_d & 0 \\ 0 & -y_c & -y_d & y_c + y_d + y_e & -y_e \\ 0 & 0 & 0 & -y_e & y_e \end{bmatrix}$$

$$- \begin{bmatrix} 0 & 0 & 0 & 0 & 0 \\ 0 & y_c & 0 & -y_c & 0 \\ 0 & 0 & 0 & 0 & 0 \\ 0 & -y_c & 0 & y_c & 0 \\ 0 & 0 & 0 & 0 & 0 \end{bmatrix} = \begin{bmatrix} y_a & -y_a & 0 & 0 & 0 \\ -y_a & y_a + y_b + y_f & -y_b & 0 & 0 \\ 0 & -y_b & y_b + y_d + y_g & -y_d & 0 \\ 0 & 0 & -y_d & y_d + y_e & -y_e \\ 0 & 0 & 0 & -y_e & y_e \end{bmatrix}$$

5. To obtain  $\underline{Y}_3$ , we Kron reduce  $\underline{Y}'_3$ , eliminating buses 2, 3, and 4, leaving only buses 1 and 5.

6. A last thing that is necessary before initiating the stability simulation is to obtain the internal voltages for all of the machines. Consider Fig. 4 below.

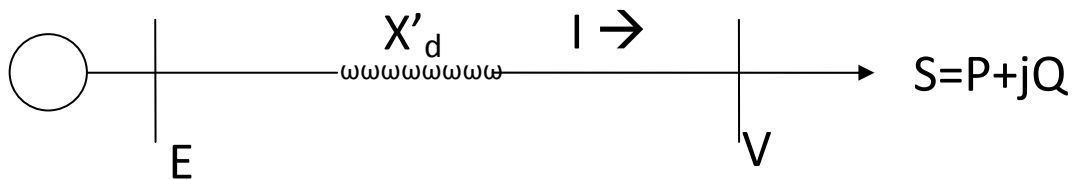

Fig. 4

From the power flow solution, we will know  $V$  and  $S$ , and so our problem now is to obtain  $E$ .

We can express complex power (in per unit) as

$$S = VI^* = P + jQ \quad (15)$$

Solving for  $I$ , we obtain

$$I = \left( \frac{P + jQ}{V} \right)^* = \frac{P - jQ}{V^*} \quad (16)$$

Then, from Fig. 4, we can express the internal voltage as

$$E = V + I(jX_d') = V + \left( \frac{P - jQ}{V^*} \right) jX_d' \quad (17)$$

Or:

$$E = V + \frac{QX_d'}{V^*} + \frac{jPX_d'}{V^*} \quad (18)$$

Equation (18) is almost the same as (2.61) in your text, which is

$$E = V + \frac{QX_d'}{V} + \frac{jPX_d'}{V} \quad (2.61, \text{ text})$$

The difference between (18) and (2.61) is that in (18), the voltage in the denominator is conjugated, whereas in (2.61), it is not. The two equations are the same under the condition that the terminal voltage  $V$  is the reference, i.e., that it has angle 0 degrees.

However, in the multi-machine case, there will be only one machine that satisfies this condition. Therefore your text suggests adjusting for this by adding the “pre-transient voltage angle” to the angle provided by (2.61). This is fine, but equation (18) makes this additional step unnecessary.

We are now in a position to consider ways of solving the swing equation accounting for the network, via numerical integration.